



SWPPP Cut Sheet

Last Updated: 1-1-08

Section 1: Erosion and Sediment Control – Construction Activities

1.9 Filtrexx Sediment Trapp™ *Sediment Control Technology*

PURPOSE & DESCRIPTION

Filtrexx Sediment Trapps™ are temporary **dry pond sediment containment detention systems** used to capture sediment and settle suspended solids in runoff from disturbed soils less than 5 acres (2 ha). Filtrexx Sediment Trapps™ are also used to capture sediment and settle suspended solids from **detention pond outfalls** and/or potential overflows.

APPLICATION

Filtrexx Sediment Trapps™ are typically installed down slope from disturbed soils where runoff capture and detention is feasible and settling of suspended solids is required. Applications include:

- Individual sediment detention and containment zones where drainage areas do not exceed 5 acres (2 ha).
- Sediment and storm water detention pond outfall channels where removal of sediments and soluble pollutants are required before final discharge.
- Emergency overflow for retention or detention sediment or storm water containment systems.
- Where land area is limited or land disturbance, grading, and/or construction of a sediment pond is undesirable or not feasible.
- Where sediment particle sizes are predominantly greater than 0.002 mm (clay).

INSTALLATION

1. Filtrexx Sediment Trapps™ shall meet Filtrexx Soxx™ Material Specifications and use Certified Filtrexx FilterMedia™.
 2. Contractor is required to be a Filtrexx Certified™ Installer as determined by Filtrexx International, LLC (440-926-2607 or visit website at Filtrexx.com). Certification shall be considered current if appropriate identification is shown during time of bid or at time of application (current listing can be found at www.filtrexx.com). Look for the Filtrexx Certified™ Installer Seal.
 3. Sediment Trapps™ will be placed at locations indicated on plans as directed by the Engineer.
 4. Sediment Trapps™ shall not be placed on fill soil or slopes, soft, or uneven ground.
 5. Sediment Trapps™ should be installed at the base of the drainage area.
 6. Filtrexx Runoff Diversion Soxx™ can be installed to divert runoff from undisturbed or stabilized areas from entering design area of Sediment Trapp™.
 7. Filtrexx Slope Interruption Soxx™ may be installed upslope and with the runoff flow path to reduce flow energy entering Filtrexx Sediment Trapps™.
 8. Concentrated flows, channels, or ditches directing flow into Sediment Trapps™ shall employ energy flow dissipaters prior to flow contact with Sediment Trapp Soxx™ or entry into the Sediment Trapp™ system. Dissipaters shall be placed at a minimum distance of 20 ft (6 m) from the base course of the Sediment Trapp™.
 9. Sediment Trapps™ shall be installed so the effective height is at least 3 ft (90 cm).
 10. Sediment Trapps™ shall be constructed so the horizontal base is at least twice the effective height (1H:1V).
 11. Sediment Trapps™ sized and specified by fascia area shall be installed so that the height is measured vertically not across the plane of the face.
 12. Additional runoff-sediment storage area can be created by over excavating the area immediately upslope of the Sediment Trapp™.
 13. Soxx™ that are sleeved to create longer lengths shall not be placed in areas of concentrated flow, at the base of channels/ditches, or at the low point with the Sediment Trapp™ system.
 14. Soxx™ that are sleeved to create longer lengths shall be overlapped by a minimum of 4 ft (120 cm) and shall be staked where material overlaps using 2 stakes, 2 ft (60 cm) apart.
 15. Stakes shall be installed through the middle of the Sediment Trapp Soxx™ using 2 in (50mm) by 2 in (50mm) by 3 ft (1m) wooden hardwood stakes on 10 ft (3 m) centers. Stakes shall be placed in a pyramid configuration perpendicular to Soxx™ where stakes cross at the apex of the Sediment Trapp™. Stakes shall be joined and secured with wire wrapping at apex using 16 gauge or multi-strand 20 gauge wire allowing 12 in (30 cm) of stake above the Soxx™. All base layers shall be staked on 5 ft (1.5 m) centers. Half inch (12.5 mm) rebar may be used when ground is frozen or extremely compacted.
 16. Staking depth for sand and silt loam soils shall be 12 in (300mm), and 8 in (200mm) for clay soils.
 17. Sediment Trapp Soxx™ to receive additional layers shall be slightly compacted and leveled.
 18. Loose compost may be backfilled along the upslope side of the Sediment Trapp™, filling the seam between the soil surface and the Sediment Trapp™, improving sediment containment efficiency and reducing undercutting potential.
 19. If the Sediment Trapp™ is to be left as a permanent filter or part of the natural landscape, it may be seeded at time of installation for establishment of permanent vegetation. The Engineer will specify seed requirements.
 20. Filtrexx Sediment Trapps™ are not to be used in perennial, ephemeral, or intermittent streams.
- See design drawing schematic for correct Filtrexx Sediment Trapp™ installation (Figure 9.1).

INSPECTION and MAINTENANCE

Routine inspection should be conducted within 24 hrs of a runoff event or as designated by the regulating authority. If ponding becomes excessive, additional Sediment Trapps™ may be required to reduce effective drainage area or sediment removal may be necessary.

1. The Contractor shall maintain the Sediment Trapp™ in a functional condition at all times and it shall be routinely inspected.
2. If the Sediment Trapp™ has been damaged, it shall be repaired, or replaced if beyond repair.
3. The Contractor shall remove sediment at the base of the upslope side of the Sediment Trapp™ when accumulation has reached 1/2 of the effective height of the Sediment Trapp™, or as directed by the Engineer. Alternatively, a new Sediment Trapp Soxx™ can be placed on top of the original structure creating more sediment storage capacity without soil disturbance.
4. Sediment Trapp™ shall be maintained until disturbed area above the device has been permanently stabilized and construction activity has ceased.
5. FilterMedia™ will be dispersed on site once disturbed area has been permanently stabilized, construction activity ceased, or determined by Engineer.

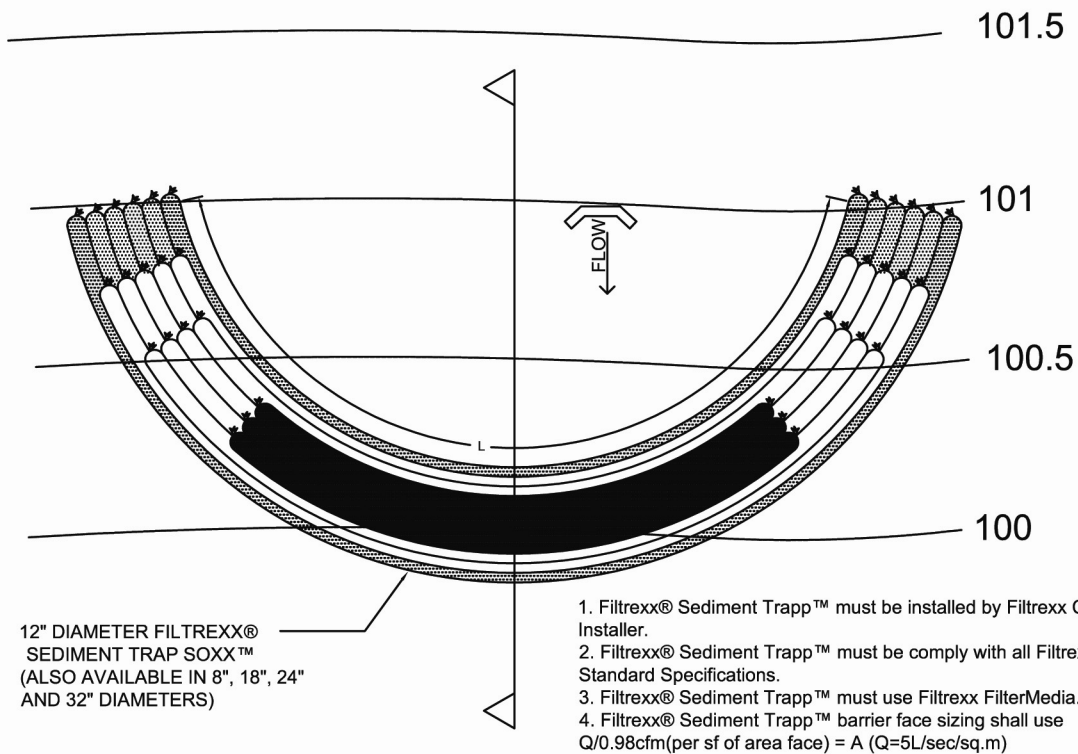

12" DIAMETER FILTREXX®
SEDIMENT TRAP SOXX™
(ALSO AVAILABLE IN 8", 18", 24"
AND 32" DIAMETERS)

PLAN

1. Filtrexx® Sediment Trapp™ must be installed by Filtrexx Certified Installer.
2. Filtrexx® Sediment Trapp™ must comply with all Filtrexx Standard Specifications.
3. Filtrexx® Sediment Trapp™ must use Filtrexx FilterMedia.
4. Filtrexx® Sediment Trapp™ barrier face sizing shall use $Q/0.98\text{cfm (per sf of area face)} = A$ ($Q=5L/\text{sec/sq.m}$)
5. Filtrexx® Sediment Trapp™ barrier face shall be measured as $A=L*D$.
6. Filtrexx® Sediment Trapp™ shall be constructed so that the minimum base width is equivalent to the height (1H:1V).
7. Sediment accumulation shall not exceed $\frac{1}{2}$ the height of the barrier.
8. Filtrexx® Sediment Trapp™ shall be inspected and maintained after storm events.
9. Socks shall be of larger diameter at the base of the Sediment Trapp™ and decrease in diameter for successive layers.
10. Ends of the Sediment Trapp™ shall be a minimum 1 ft (30 cm) higher in elevation than the mid-section, which shall be at the lowest elevation.
11. Bottom layer of Sox™ shall be staked with 2x2x36" wooden stakes. Successive layers shall be staked with $\frac{1}{2}$ " rebar at a 45 degree angle.

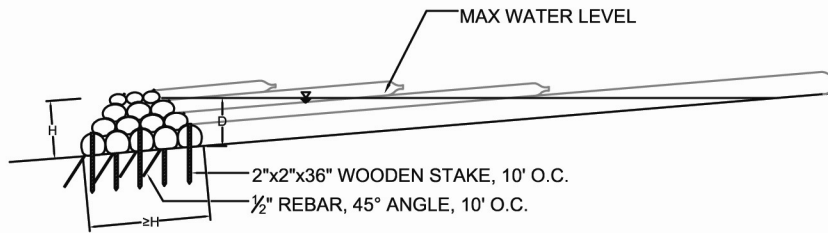

SECTION

FILTREXX® SEDIMENT TRAPP™